

**Safety Instructions &
Operator's Manual
for**

SNAPPER®

**3201 SERIES SINGLE STAGE
SNOW THROWERS**

THANK YOU for buying a SNAPPER product! Your SNAPPER Snow Thrower was designed and built to provide long and satisfactory service. Keep in mind that it, like any other mechanical device, can be potentially dangerous if used improperly and that no accident prevention program can be successful without the wholehearted co-operation of the person responsible for the operation of the equipment. Study this Operator's Manual carefully to learn about operation of all controls and pay particular attention to the Important Safety Precautions on page 2. Following these instructions will help you continue to enjoy the trouble-free operation expected of a SNAPPER product.

INTRODUCTION

The Snapper model 3201 single stage Snow thrower is powered by a 3HP two cycle engine which requires an exact mixture of oil and gasoline to provide internal lubrication of the engine. Since several different makes of engines are used to power the 3201, refer to the engine manual which accompanies your unit for the specific fuel ratio and other important details.

Save these manuals and review at the start of each new season. Pay particular attention to the Important Safety Instructions and to the warning decals on the unit.

The 3201 will clear a path approximately twenty inches wide and will throw the snow from 3 to 18 feet away depending on the setting of the discharge deflector and conditions of the snow. The light weight of the unit allows easy lifting for sweeping steps and porches. The quart capacity tank holds sufficient fuel for 1 to 1-½ hours operation depending upon load conditions.

SNAPPER POWER EQUIPMENT

McDonough, GA • 30253





SAFETY INSTRUCTIONS



WARNING: This powerful snow thrower is capable of amputating hands and feet and of throwing objects causing injury. Read this manual carefully and question your Snapper Dealer if something is not clear. Should the dealer be unable to answer to your satisfaction, send a letter to the Snapper Customer Service Department at Snapper Power Equipment, Post Office Box 777, McDonough, Georgia 30253, or Phone 1-404-957-9141.

PROTECTION FOR CHILDREN

1. DO NOT allow children in area when Snow Thrower is being operated.
2. DO NOT allow pre-teen children to operate Snow Thrower.
3. DO NOT allow irresponsible teenagers to operate the machine — allow teenager only if exhibiting mature judgement and then only after thorough instruction and under close supervision of an experienced operator.

PREPARATION

1. Read this manual, get to know where all controls are located and practice how to use them before starting for the first time and at the beginning of each season. Pay attention to Decals on engine and snow thrower.
2. Wear protective clothing including face mask and boots which will give you maximum footing on slippery surfaces.
3. Before the first snow fall, check the area to be cleared and remove all objects such as doormats, sticks, toys, wires, rocks, etc., which could be hurled or jam the snow thrower.
4. Survey the area to be cleared beforehand and plan where snow is to be blown. Be prepared to release blower clutch or to change deflector quickly to discharge away from windows, cars, buildings and doorways to avoid property damage or personal injury from hurled objects.
5. Handle fuel with care. Store only in approved gasoline container. Move machine outdoors where fumes can be safely dissipated before filling tank. Never add fuel when engine is running. Allow cooling off period after stopping to avoid spilled fuel from igniting on contact with hot engine parts.

OPERATIONAL PRECAUTIONS

1. Before starting, make visual check to make sure blower housing is clear and all guards and shields are in place and tight.
2. Warn everyone in advance to stay clear of area but keep especially watchful for children and pets darting into area while operating.
3. Start engine only when exhaust fumes can be dissipated, allow brief warm-up period, practice operation of controls outside before putting the machine to work.
4. Should the blower become clogged, release auger clutch control and, as an additional precaution, stop the engine before attempting to unclog the collector or discharge chute.
5. If you strike a hard object, stop the engine and disconnect the spark plug wire before inspecting for damage.
6. Stop the engine if unit starts to vibrate excessively as this normally indicates mechanical problems. Disconnect the spark plug wire to prevent unintentional starting before servicing or repairing the machine.
7. Avoid clearing steep slopes and keep away from drop-off areas where footing is doubtful or where the machine could tip over. Clear snow across the face of slopes whenever possible.
8. Stop the engine and remove the key whenever you leave the unit unattended to eliminate the possibility of children or untrained adults attempting to operate the machine.
9. Release clutch control and make sure auger has stopped before rotating discharge chute, adjusting deflector, or placing hands near auger.

OPERATING INSTRUCTIONS

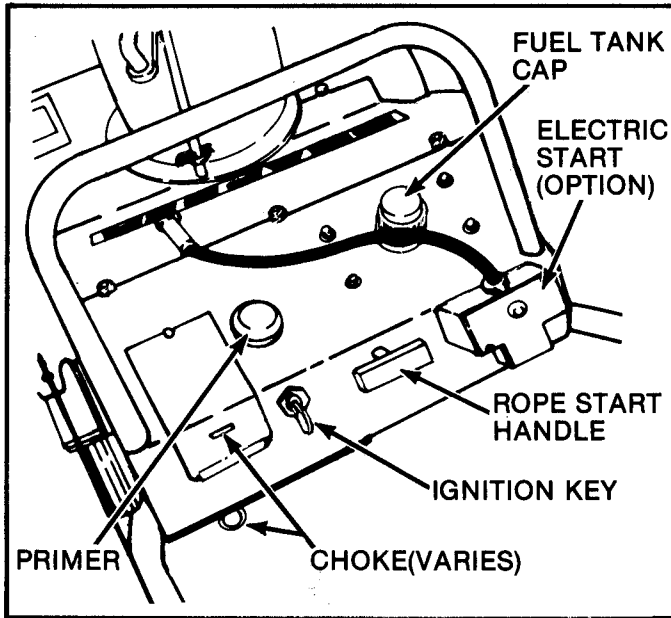

FIGURE 1 - LOCATION OF PANEL CONTROLS

PRE-START CHECKS

- **FUEL** with unit safely away from ignition producing appliances and in well ventilated area where fumes can be dissipated, fill fuel tank with correct gasoline/oil mixture as specified in the engine owner's manual.
- **CHECK GUARDS & COVERS** to make sure all are in position and securely tightened.
- **CHECK AUGER CLUTCH** to make sure control operates freely without binding.
- **CHECK BLOWER HOUSING** to make sure it is completely free of rags, toys or other objects which could be thrown or block operation of the augers.

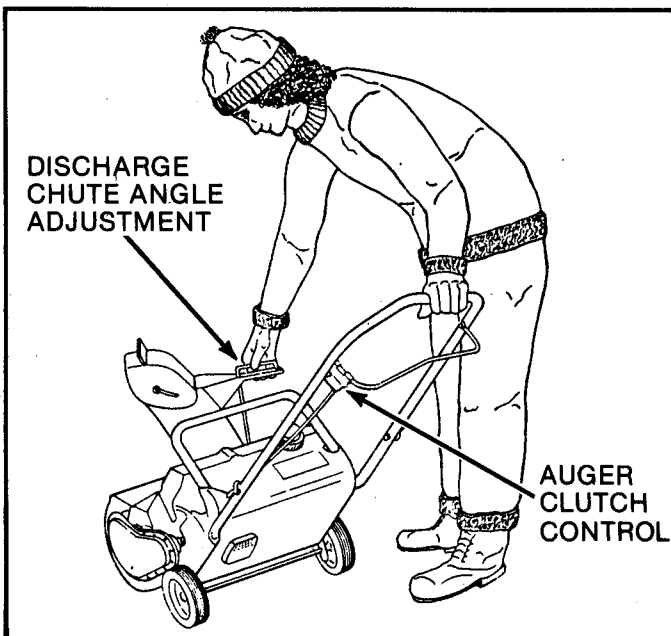

FIGURE 2 - DISCHARGE & BLOWER CONTROLS

OPERATION

Know how to stop the auger and engine quickly in preparation for possible emergencies! The auger is stopped by releasing the auger clutch control and the engine is stopped by turning the key in ignition switch to off position.

STARTING-STOPPING ENGINE: The engine is stopped by turning the ignition key to OFF. Always remove the key from the switch when leaving the machine. Start the engine as follows after performing the foregoing pre-start checks and services.

1. **PRIME** engine as instructed in the engine owners manual.
2. **CHOKER** by pulling choke control out.
3. **IGNITION:** turn engine ignition key to ON.
4. **ROPE START:** Pull starter handle with smooth rapid movement until engine starts. If engine fires but does not start after repeated attempts, push choke control in and pull starter handle again. Do not allow handle to snap back.
5. **ELECTRIC START (OPTION)** Connect power cord to starter switch box on panel then plug the other end into a 120 volt AC receptacle. Push starter button in until engine starts—do not hold button for more than twenty seconds to avoid damaging starting motor. After engine starts, disconnect power cord from the AC receptacle first then unplug from the switch box on the snow thrower.

OPERATIONAL HINTS

After the engine has warmed sufficiently, start the augers by pulling the auger clutch control back to the handle. Release the control to stop the augers.

The rubber strips attached to the edges of the augers help pull the Snow Thrower forward. Push down on the handles to raise the strips above the surface to stop forward motion. In especially heavy snow, moving the Snow Thrower back and forth may help clear the first path. Overlap as needed to suit snow conditions.

SERVICE PROCEDURE

Contact your Snapper Dealer for service assistance and/or replacement parts for your Snow Thrower. Your unit will have either a Briggs & Stratton or Tecumseh two-cycle engine. Contact the engine dealer for engine service.

STORAGE-OFF SEASON

Before storing the unit for the off season, operate the engine until it runs out of fuel. If this is not done, oil in the gasoline will gather in the carburetor making starting very difficult at the beginning of the next season. Refer to the engine owner's manual for specific storage instructions. Cover the unit and store in clean, dry area.

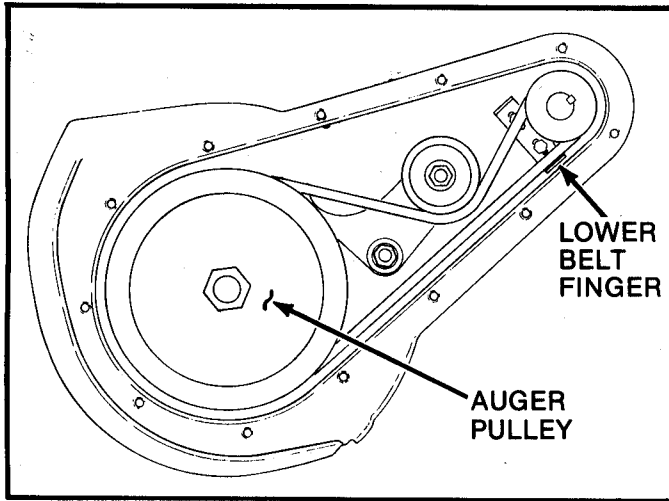

FIGURE 3 - AUGER CLUTCH-BELT ARRANGEMENT

AUGER CLUTCH ADJUSTMENT: Pull the clutch control up against the handle & note the cable. If the cable is slack with the control held against the handle, release the control, loosen the nut & increase the tension by turning the cable or turn buckle on lower end. Proper idler tension is achieved when cable spring is extended 3/8 to 1/2" when clutch con-

trol is held against handle. Release clutch control & note cable. The cable should be slack with control released.

If auger does not clutch properly with bail released after above adjustment, it may be necessary to adjust belt fingers inside belt drive housing. Remove cover by removing #10 fasteners. Belt fingers are at upper end near engine pulley. With bail drawn up to handle, belt should clear lower finger by 1/16". If adjustment is necessary, loosen belt finger screws and slide up or down as required. Further adjustment is achieved by bending fingers. **Note:** Complete clutching action: Idler releases, brake is applied & belt comes free of driver.

BELT REPLACEMENT: Should the belt need replacing, remove the belt guard, loosen the large 6" auger pulley just enough to slip the old belt off and the new belt on, then retighten after routing the belt over the pulleys. **NOTE:** The auger pulley is loosened by turning clockwise and tightened by turning counter-clockwise which is the opposite of normal direction. Reinstall the belt cover. Check and readjust clutch cable tension as needed after operating for a few hours as the new belt may stretch or wear in. Use Snapper part number 1-4637 belt.

MANUFACTURER'S 2 YEAR LIMITED WARRANTY

For two (2) Years from purchase date for the original purchaser's residential, non-commercial use [ninety (90) days from purchase date for the original purchaser's commercial, rental, or other non-residential use], SNAPPER POWER EQUIPMENT, through any SNAPPER dealer will replace, free of charge, any part or parts found upon examination by the factory at McDonough, Georgia, to be defective in material or workmanship or both.

All transportation cost incurred by the purchaser in submitting material to a SNAPPER dealer for replacement under this warranty must be borne by the purchaser.

This warranty does not apply to engines and their components, as these items are warranted separately by their manufacturers, and does not apply to batteries which are covered separately. This warranty does not apply to parts that have been damaged by accident, alteration, abuse, improper lubrication, normal wear, or other cause beyond our control.

There is no other express warranty.

Implied warranties, including those of merchantability and fitness for a particular purpose, are limited to two (2) years from purchase date for the original purchaser's residential, non-commercial use [ninety (90) days from purchase for the original purchaser's commercial, rental or other non-residential use], and to the extent permitted by law any and all implied warranties are excluded. This is the exclusive remedy. Liabilities for consequential damages, under any and all warranties are excluded.

Some states do not allow limitations on how long an implied warranty lasts, or do not allow the exclusion or limitation of incidental or consequential damages, so the above limitation or exclusion may not apply to you.

This warranty gives you specific legal rights, and you may also have other rights which vary from state to state.

WARNING: THE USE OF REPLACEMENT PARTS OTHER THAN GENUINE SNAPPER PARTS MAY IMPAIR THE SAFETY OF SNAPPER PRODUCTS AND WILL VOID ANY LIABILITY AND WARRANTY BY SNAPPER ASSOCIATED WITH THE USE OF SUCH PARTS.

IMPORTANT: Please fill out the attached SNAPPER Product Registration Card immediately and mail to: **SNAPPER POWER EQUIPMENT, McDONOUGH, GEORGIA 30253**